

The Bracket Mount Mixer provides a means of mounting a mixer to a tank cover or other flat surface. Four 18/8 stainless steel bolts and two rugged 3/8" thick steel brackets hold the mixer securely in place, requiring no additional mixer supports.

Construction

All mixers feature a 316 stainless steel shaft with an integral impeller (dual impellers standard on 48" shafts). Special epoxy and vinyl shaft coatings are available for applications where the solution being agitated is not compatible with 316 stainless steel. The shaft is coupled to the motor via a brass adapter which is held securely by four stainless steel set screws.

The mounting bracket is constructed of steel with a corrosion resistant coating and all fasteners are 18/8 stainless steel.

Installation

For use without mixer support: Measure the impeller diameter and cut a hole of the appropriate size in the tank lid. Hole should be located so mixer shaft does not make contact with tank wall. Next place the motor (with brackets attached) do that the shaft is centered over the hole that was drilled in the proceeding step. Using the bracket holes as a guide, mark the tank cover. Remove mixer assembly. Drill holes large enough for the fasteners in the four marked locations. Reinstall the mixer assembly and fasten securely to the tank cover with the four bolts provided.

Mounting with top support ring: When the Tank System is ordered with a top support ring (TSR), a mounting plate is provided for the bracket mount mixer. The bracket assemblies are removed and the motor mounts directly to the mounting plate of the top support ring. Cut hole in tank lid to accommodate the mixer shaft.

Features

- 316 SS Shaft
- Epoxy and Vinyl Shaft Coatings Are Available
- Shafts Cut to Length

Operating Benefits

- Bracket mount eliminates the need for additional mixer support.
- Simple Installation.



Aftermarket

- Double Wall Containment Tanks from 15 to 500 gallons.
- 1, 2, or 4 Drum Spill Containment Pallets.
- Metering Pumps.



Bracket Mount Mixer

Bracket Mount Mixer

Specifications and Model Selection

Bracket Mount Mixer Selection Guide	
MOUNT:	B = Bracket Mount Mixer
HORSEPOWER:	M = 1/20 1 = 1/4 2 = 1/3 3 = 1/2 4 = 1
TYPE:	0 = Open Drip Proof TE = Totally Enclosed EXP = Explosion Proof
SHAFT:	H = 316 Stainless Steel
AVAILABLE OPTIONS:	WRD = 6' 3 w ire 18 gauge SJ cord and plug installed at factory EPOXY = Special epoxy corrosion resistant coating for stainless steel impeller and shaft VINYL = Special vinyl corrosion resistant coating for stainless steel impeller and shaft recommended for sodium hypochlorite 230 = 230V Motor LENGTH = Length in inches represents shaft length requested Suction Tube Shield Assembly. 1" PVC tube, prevents pump suctiontubing from entangling with mixer blade. 28655 = 29" - 55 gallon 28656 = 20" - 35 gallon
A completed model number should look like 'B-3-TE-H/VINYL, 36'''	

Engineering Data

Type	OPEN								TOTALLY ENCLOSED								EXPLOSION PROOF								
Shaft Length*	34	36	44	48	28	34	36	44	48	34	36	44	48	34	36	44	48	34	36	44	48	34	36	44	48
Horsepower	1/4	1/3	1/2	1	1/20	1/4	1/3	1/2	1	1/4	1/3	1/2	1	1/4	1/3	1/2	1	1/4	1/3	1/2	1	1/4	1/3	1/2	1
RPM	1725								1500	1725															
Voltage	115	250	115	230	115	230	115	230	115	115	230	115	230	115	230	115	230	115	230	115	230	115	230	115	230
Amperage**	6.2	3.1	6.8	3.4	8.2	4.1	14.8	7.4	2.0	5.2	2.6	6.8	3.4	9.6	4.8	13.6	6.8	4.5	2.3	6.8	3.4	9.0	4.5	13.6	6.8
Motor Design	- split phase - sleeve bearings 1 HP motors - capacitor start								1/20 HP Motors - ball bearing - shaded pole - totally enclosed air open All Other Motors - ball bearing - automatic overload - capacitor start - fan cooled								- split phase - ball bearing - non ventilated 1 HP Motors - automatic overload - capacitor start - fan cooled								

* Shafts may be cut to desired length. 44" and 48" shafts feature dual impellers.

** 50 Hz models available, consult factory.

Mount Detail

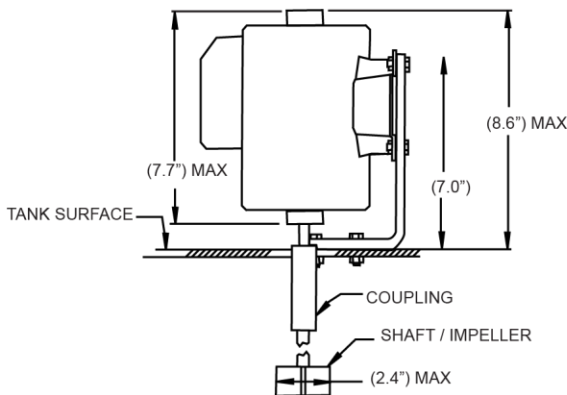

pulsafeeder.com



27101 Airport Rd
 Punta Gorda, FL 33982
 Phone: ++1(941) 575-3800
 Fax: ++1(941) 575-4085

An ISO 9001 and ISO 14001 Certified Company



BMM001 B12