

The Pulsafeeder Pump Containment Shelf protects metering pumps from harsh environmental conditions while offering peace of mind from potential hazardous material leaks. Almost any leak will be safely contained via a drain line from your Pump Containment Shelf back into your Dual-Containment Tank System.

Features

- Integral containment captures spills and allows for drainage back into your Tank System.
- High Density Polyethylene construction will not rust or corrode.
- Suitable for use with most water treatment chemicals.
- Heavy-Duty construction - 250# rating-Can also be used as a step.
- Pump Containment Shelf maybe mounted on a wall, on top of a tank or any other convenient location.
- Mounting holes for easy installation.
- 1-1/2" diameter holes on sidewalls allow for easy connection of chemical tubing and electrical connections.

Aftermarket

- Double Wall Containment Tanks from 15 to 500 gallons.
- 1, 2, or 4 Drum Spill Containment Pallets.
- Loading Ramp and Pallet with or without Cover.

Operating Benefits

- Heavy-Duty rubber feet included for non-slip use on any level surface.
- Modular design allows for mounting multiple pump shelves together in one convenient location.
- Slide-out pump base makes mounting and servicing pumps easy.
- Raised pump base keeps pumps elevated and isolated from contamination caused by leaking fittings or pump failure.



Pump Containment Shelf

Pump Containment Shelf

Materials of Construction:

Body:	Polyethylene
Slide-out Shelf:	Polyethylene
Drain Connection:	1/4" Stainless Steel
Feet:	SBR Rubber
Dimensions:	(nominal)
Height:	19" (excluding optional feet)
Width:	19"
Depth:	16-1/2"
Shipping Weight:	15 pounds
Standard Color:	Blue

Dimensions

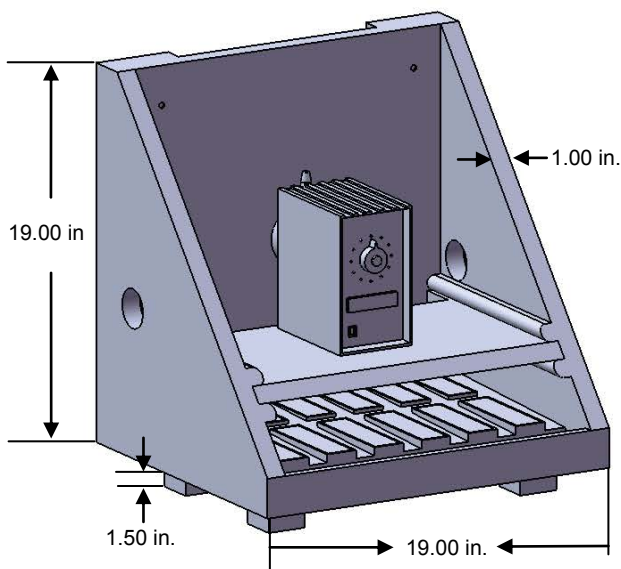

pulsafeeder.com



27101 Airport Rd
Punta Gorda, FL 33982
Phone: ++1(941) 575-3800
Fax: ++1(941) 575-4085

An ISO 9001 and ISO 14001 Certified Company



CS001 H10