

Pulsafeeder's Digital Glycol Feeder provides a consistent operating pressure in closed loop systems. This allows a controlled percentage of glycol solution to be fed from the 55 gallon tank. The Digital Glycol Feeder is available in two models; the DGF1 for single loop and the DGF2 for dual loop systems.

The control unit utilizes an 8-bit microcontroller for precise feed system control. The NEMA4X enclosure can be wired conduit or prewire for easy startup. The preplumbed assembly includes a pressure gauge, pressure switch, and pressure relief valve to prevent excessive pressure build up. A low liquid level switch with optional audible alarm prevents the gear pump from operating when the solution is low.

Each Digital Glycol Feeder is fully piped and wired with the following components:

**Suction Assembly includes:**

- PVC tubing and fittings
- PVC ball valve
- Clear poly bowl strainer

**Discharge Assembly Includes:**

- PVC pipe and fittings
- PVC ball valve
- PVC check valve
- Pressure gauge
- Brass relief valve with return to tank tubing

**Features**

**Controller Features**

- Touch Keypad User Interface for Gear Pump Operation
- LED Indicators Loss of Pressure and Low Level
- HOA Control Of Pumps and Alarm To Force Relay OFF Indefinitely Or Force Relay ON For A Period Of 5 Minutes
- Alarm Silence Feature
- Dual Alarm Relay Outputs Are Factory Configured For Dry Contact Or Powered
- Available In 115V Or 230V

**Pump Features**

- Heavy Duty Gear Pump
- Bronze And Stainless Steel Wetted Components
- Close Tolerance Design Allows For Consistent Performance
- Helical Gears For Quiet Operation

**System Features**

- Economical Design For Competitive Bid Specifications

**Operating Benefits**

- Provides consistent operating pressure in closed loop systems.
- Fully piped and wired.
- Agency approved for US and Canada.
- NEMA 4X enclosure.



**Aftermarket**

- Metering Pumps
- Cooling Tower Controllers
- Boiler Controllers
- Pre-Engineered Systems



**Digital Glycol Feeder**

# Digital Glycol Feeder

## Specifications and Model Selection

DIGITAL GLYCOL FEEDER Selection Guide		DGF	-	-	-	-	-	-
<b>CLOSED LOOPS</b> Position 4	1 = Single Loop 2 = Dual Loop							
<b>CONDUIT / PREWIRE</b> Position 5	A = Conduit B = Prewire							
<b>AUDIBLE ALARM</b> Position 6	A = without Audible Alarm B = with Audible Alarm							
<b>ALARM OUTPUT OPTION</b> Position 7	X = None A = Dry Contact, Single B = Dry Contact, Dual C = AC Output, Single D = AC Output, Dual E = Dry Contact, Single & AC Output, Single							
<b>PRESSURE SWITCH OPTION</b> Position 8	A = Standard pressure switch, 30 to 50 psi (adjustable to 80 psi) B = Low pressure switch, 5 to 10 psi (adjustable to 35 psi) C = One standard and one low pressure switch (DGF2 only)							
<b>PUMP AND VOLTAGE RATING</b> Position 9	A = 115VAC no pump B = 230VAC no pump (must be conduit) C = 115VAC 60Hz 1.50GPM @ 100psi E = 115VAC 60Hz 3.75GPM @ 100 psi							
<b>AGENCY APPROVAL</b> Position 10	X = None A = ETL Approval							
<b>PANEL ASSEMBLY</b> Position 11	B = Assembled (must ship via freight)							

### Engineering Data

Operating Temperature: 32°F to 122°F  
(0°C to 50°C)

System Temperature: -20°F to 140°F  
(-20°C to 60°C)

Enclosure Rating: NEMA 4X

### Dimensions

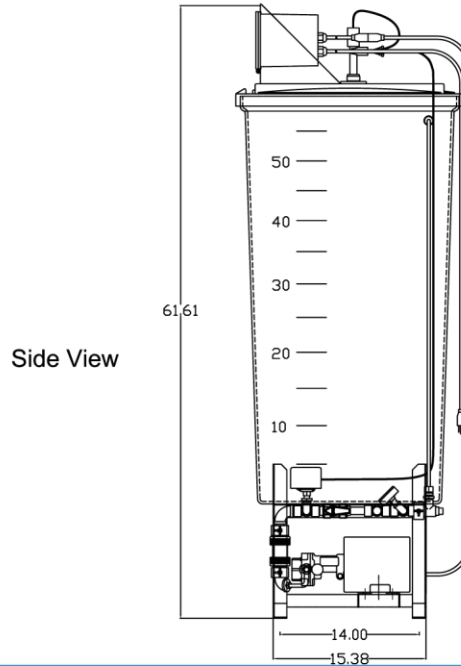
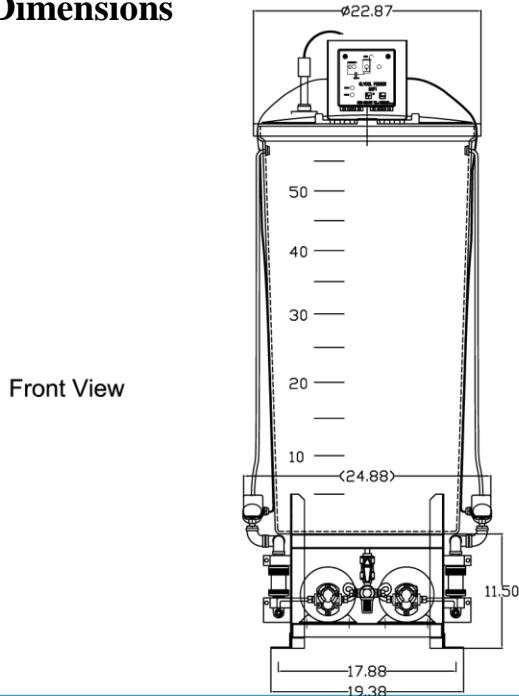

[pulsafeeder.com](http://pulsafeeder.com)

**PULSAFEEDER**  
27101 Airport Rd  
Punta Gorda, FL 33982  
Phone: ++1(941) 575-3800  
Fax: ++1(941) 575-4085

An ISO 9001 and ISO 14001 Certified Company

**ICEX**  
CORPORATION

DGF001 D12