

Pulsafeeder's ITS System is a completely integrated tank system constructed of UV resistant polyethylene (PE) with a 15 gallon capacity. This tank system is translucent with 5 gallon increments and the tank's low level indicator allows visual monitoring of chemicals without opening the tank. The tight fitting child proof lid keeps the chemical free of contaminants and protects the surrounding area from chemical fumes.

The ITS System also allows for easy access to the liquid end and control panel of the mounted pump.

A system consists of a chemical tank with lid and bulkhead fittings: a liquid level indicator float assembly and feeder mounting hardware.

Features

- **Liquid Level Wand:** The tank's low level indicator allows visual monitoring of chemical supply without opening the tank.
- **Child Proof Lid:** The tight fitting lid keeps the chemical free of contaminants.
- **Flooded Suction:** The flooded suction allows for continuous pumping without loss of prime.
- **Universal Pump Mount:** The "ITS" is predrilled for all pumps listed.
- **Built-in Grip:** For easy lifting and moving of ITS System.
- **Optional Shut-Off Valve:** Available in PVC, allows maintenance on metering pump without emptying chemical.

Operating Benefits

- Simple installation.
- Easy to maintain with low level indicator.
- Secure tight fitting lid.



Aftermarket

- Water Meters
- Gauges
- Dampeners
- Metering Pumps
- Pressure Relief Valves
- KOPkits
- Pre-Engineered Systems



Integrated Tank Systems

Integrated Tank Systems Specifications and Model Selection

ITS Tank Systems					
Size Gallons	Pump Type	Pump Series	Housing	Tube Conn. Size	System Part No.
15	Chem-Tech	XP	N/A	1/4"	J63063
		Series 100		3/8"	J40489
				1/2"	J40490
	PULSAtron	"J" conn.	Series A+, C, C+, E (except below)	3/8"	J40491
		#1 conn.		3/8"	J40492
		"A" conn.		1/2"	J40493
		"J" conn.	E (LE33-44) and E+	3/8"	J40494
		#1 conn.		3/8"	J40495
		#3 conn.		1/2"	J40496

Custom Engineered Designs – Pre-Engineered Systems

Pre-Engineered Systems

Pulsafeeder's Pre-Engineered Systems are designed to provide complete chemical feed solutions for all electronic metering applications. From stand alone simplex pH control applications to full-featured, redundant sodium hypochlorite disinfection metering, these rugged fabricated assemblies offer turn-key simplicity and industrial-grade durability. The UV-stabilized, high-grade HDPE frame offers maximum chemical compatibility and structural rigidity. Each system is factory assembled and hydrostatically tested prior to shipment.



Dimensions

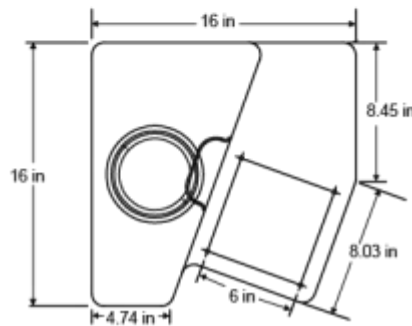
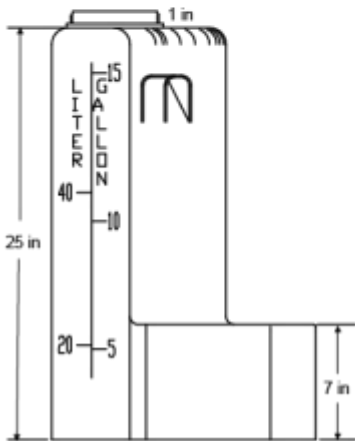

pulsafeeder.com



27101 Airport Rd
Punta Gorda, FL 33982
Phone: ++1(941) 575-3800
Fax: ++1(941) 575-4085



An ISO 9001 and ISO 14001 Certified Company

ITS001 D12