

REVISIONS			
REV.	DESCRIPTION	DATE	APPROVED
A	RELEASE ECO 00091	01-10-08	MD
B	DESIGN OPTIMIZATION ECO 00203	10-14-08	MD

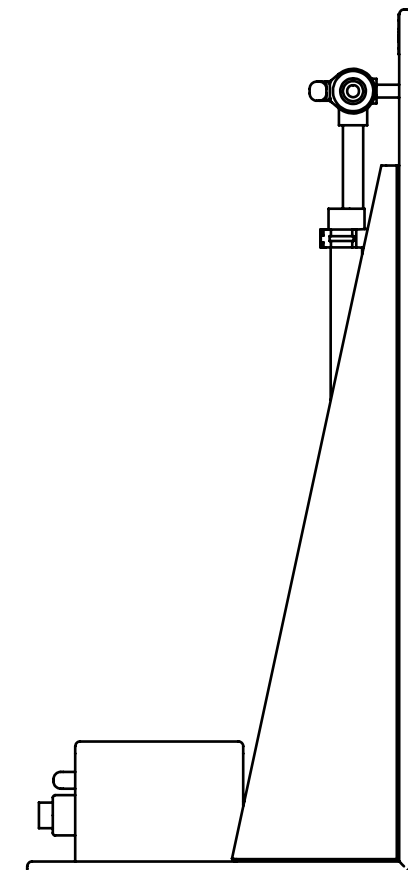
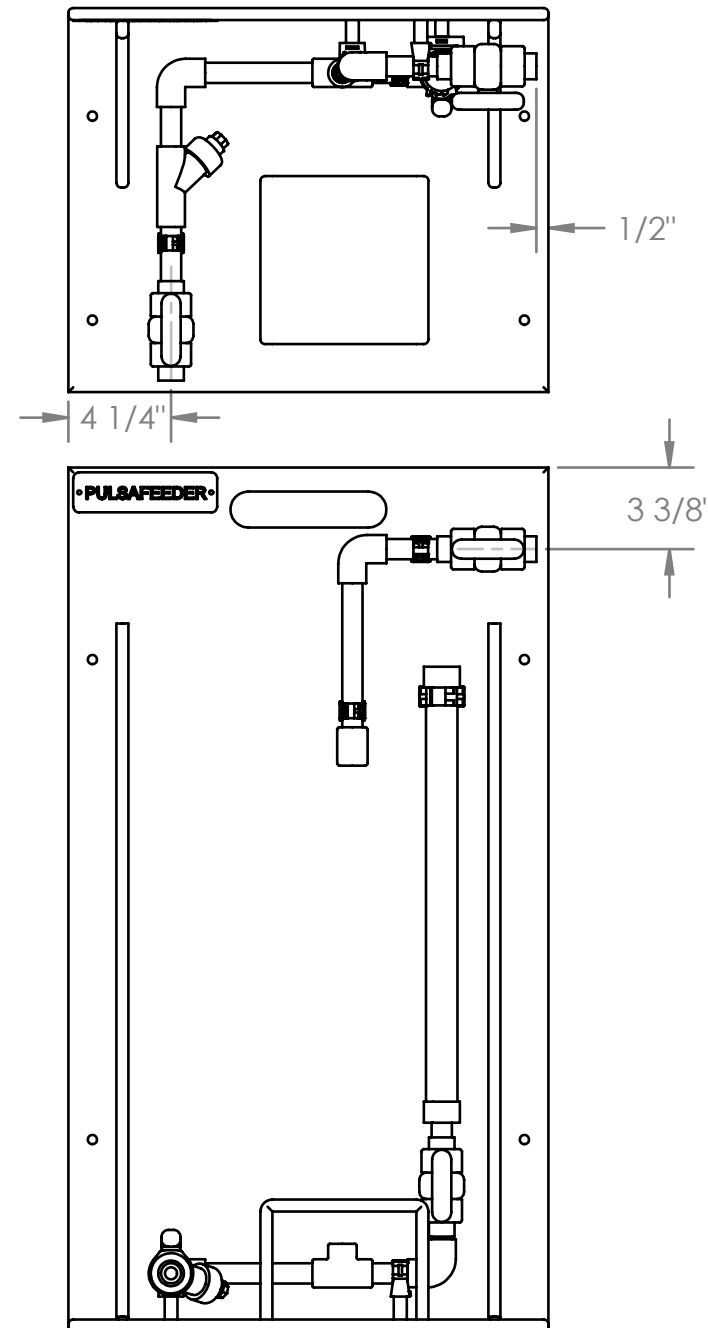

BILL OF MATERIAL

ITEM NO.	PART NUMBER	DESCRIPTION	QTY.
1	PES00007	FRAME, SIMPLEX/BASIC	1
2	PES00020-002	PIPING ASSEMBLY, INLET, (EPDM SEALS)	1
3	PES00021-002	PIPING ASSY, CHEMICAL OUTLET (EPDM SEALS)	1
4	J25334	PULSAFEEDER NAME PLATE	1
5	U0810386	#10-32 X 1" LNG SCREW	4
6	L9804000-000	#10-32 LOCK NUT	4
7	U0900857	SCREW, (SST), 6-20 X .38 TYPE-BT PHP	2
8	06-011-02	#10-32 TEE NUT	6
9	U0810036	#10-32 X 1.7" SCREW	6
10	L9801300-188	#10 FLAT WASHER	6

UNLESS OTHERWISE SPECIFIED:
 DIMENSIONS ARE IN INCHES
 TOLERANCES:
 FRACTIONAL: ±1/64
 ANGULAR: ± 1/2°
 X.X=.050in.
 X.XX=.015in.
 X.XXX=.005in.

INTERPRET GEOMETRIC TOLERANCING PER: ASME Y14.5M-1994

MATERIAL: (SEE NOTES)

FINISH: (SEE NOTES)

DO NOT SCALE DRAWING

PROPRIETARY AND CONFIDENTIAL
 THE INFORMATION CONTAINED IN THIS DRAWING IS THE SOLE PROPERTY OF PULSAFEEDER SPO. ANY REPRODUCTION IN PART OR AS A WHOLE WITHOUT THE WRITTEN PERMISSION OF PULSAFEEDER IS PROHIBITED.

	NAME	DATE
DRAWN	PEC	12-17-07
ENG APPR.	MD	01-10-08

COMMENTS:



TITLE:
**SKID ASSEMBLY,
 SIMPLEX/BASIC
 (EPDM SEALS)**

SIZE	DWG. NO.	REV
B	PES1B-E	B

SCALE: 1:1

SHEET 1 OF 1