

REVISIONS			
REV.	DESCRIPTION	DATE	APPROVED
A	RELEASE ECO 00091	01-10-08	MD
B	DESIGN OPTIMIZATION ECO 00203	10-15-08	MD

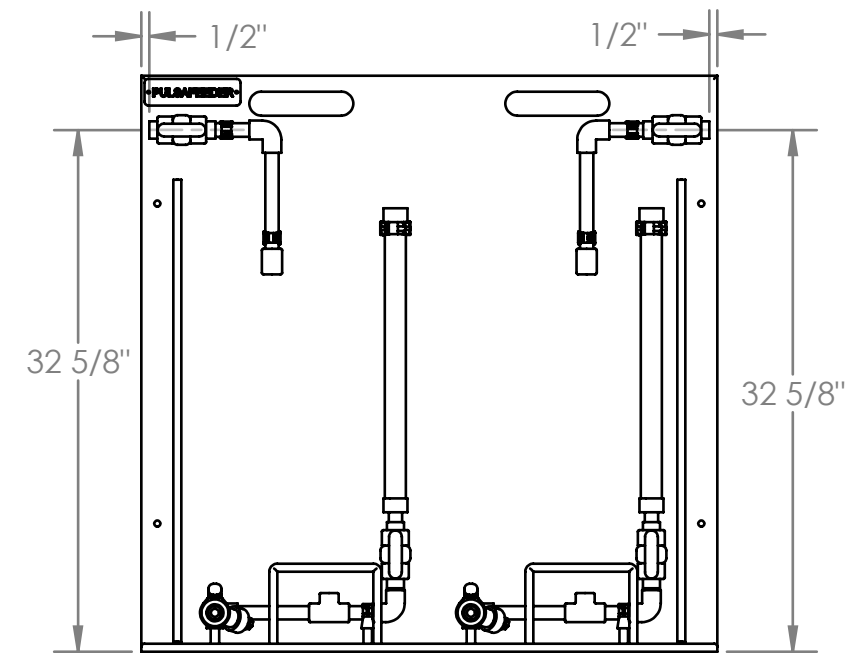
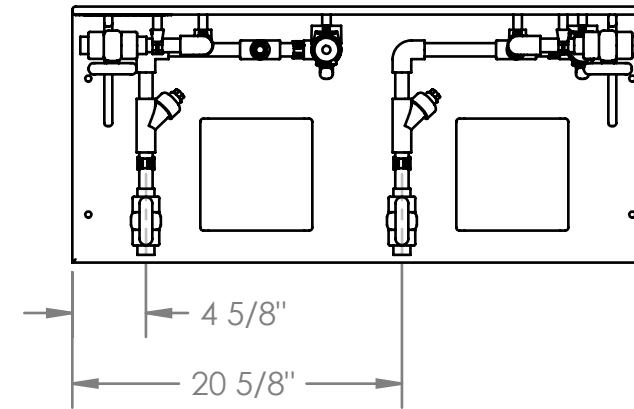

BILL OF MATERIAL

ITEM NO.	PART NUMBER	DESCRIPTION	QTY.
1	PES00017	SKID BASE WELDMENT, (BASIC/DUPLEX)	1
2	PES00020-002	PIPING ASSEMBLY, INLET, (EPDM SEALS)	2
3	PES00021-002	PIPING ASSY, CHEMICAL OUTLET (EPDM SEALS)	1
4	PES00022-002	PIPING ASSY, CHEMICAL OUTLET LT (EPDM SEALS)	1
5	J25334	PULSAFEEDER NAME PLATE	1
6	U0810386	SCREW, #10-32 X 1" PHP	8
7	L9804000-000	#10-32 LOCKNUT	8
8	U0810036	SCREW, #10-32 X 1.7" PHP	10
9	L9801300-188	#10 FLAT WASHER	10
10	06-011-02	#10-32 TEE NUT	10
11	U0900857	SCREW, 6-20 X .38 TYPE-BT PHP	2

UNLESS OTHERWISE SPECIFIED:

DIMENSIONS ARE IN INCHES  
 TOLERANCES:  
 FRACTIONAL: ±1/64  
 ANGULAR: ± 1/2°  
 X.X=.050in.  
 X.XX=.015in.  
 X.XXX=.005in.

INTERPRET GEOMETRIC TOLERANCING PER: ASME Y14.5M-1994

MATERIAL (SEE NOTES)

FINISH (SEE NOTES)

DO NOT SCALE DRAWING

	NAME	DATE
DRAWN	PEC	12-17-07
ENG APPR.	MD	01-10-08

COMMENTS:



TITLE:  
**SKID ASSEMBLY, DUPLEX/BASIC (EPDM SEALS)**

SIZE	DWG. NO.	REV
<b>B</b>	<b>PES2B-E</b>	B

SCALE: 1:1 SHEET 1 OF 1

PROPRIETARY AND CONFIDENTIAL THE INFORMATION CONTAINED IN THIS DRAWING IS THE SOLE PROPERTY OF PULSAFEEDER SPO. ANY REPRODUCTION IN PART OR AS A WHOLE WITHOUT THE WRITTEN PERMISSION OF PULSAFEEDER IS PROHIBITED.