

REVISIONS			
REV.	DESCRIPTION	DATE	APPROVED
A	RELEASE ECO 00091	01-10-08	MD
B	DESIGN OPTIMIZATION ECO 00203	10-14-08	MD
C	ADD LONGER SCREWS FOR NEW SPACERS ECO 00334	01/08/10	JH

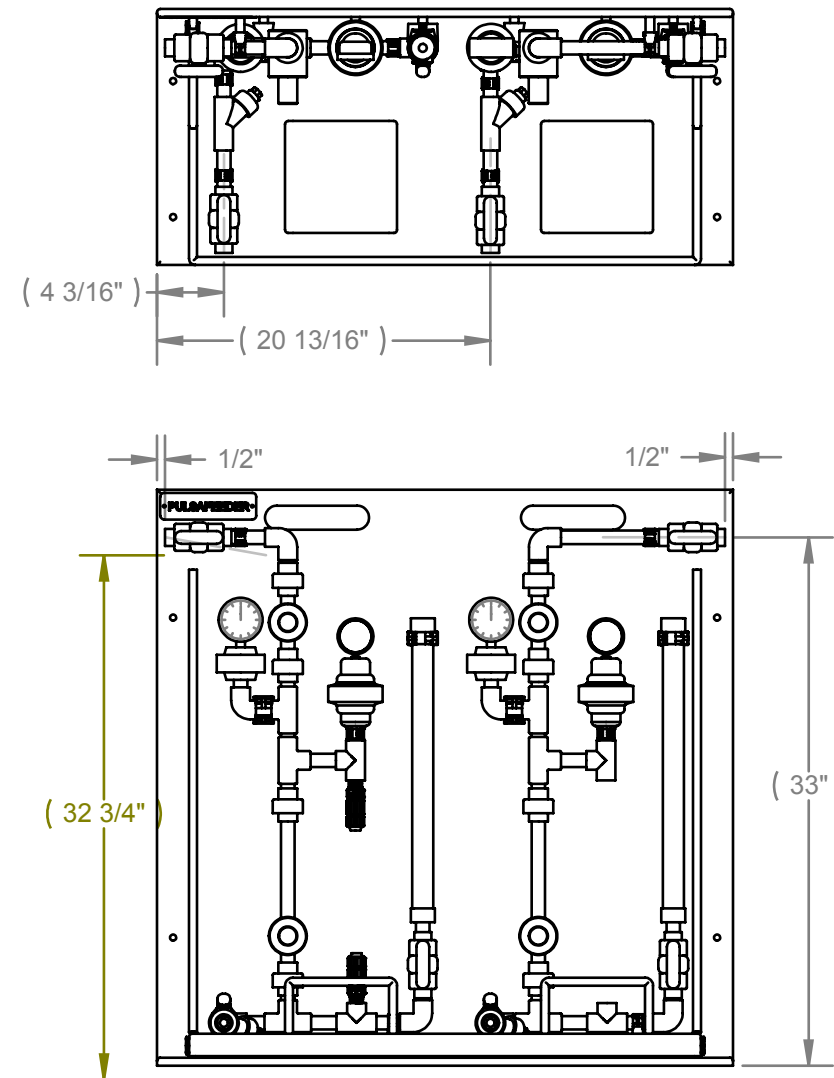

BILL OF MATERIAL

ITEM NO.	PART NUMBER	DESCRIPTION	QTY.
1	PES00013	SKID BASE WELDMENT, (STANDARD/DUPLEX)	1
2	PES00019-001	PIPING ASSEMBLY, DUPLEX LT - STANDARD (VITON SEALS)	1
3	PES00018-001	PIPING ASSEMBLY, SIMPLEX/DUPLEX RT - STANDARD (VITON SEALS)	1
4	03-043-00	PLUG, PVC-80, 1/2" T	2
5	J25334	PULSAFEEDER NAME PLATE	1
6	06-011-02	#10-32 TEE NUT	14
7	U0810036	SCREW #10-32 X 1.7"	8
8	L9801300-188	#10 FLAT WASHER	14
9	U0810386	SCREW, #10-32 X 1"	8
10	L9804000-000	#10-32 LOCK NUT	8
11	U0900857	SCREW, (SST) 6-20 X .38 TYPE-BT PHP	2
12	L9803300-188	SCREW(SST), #10-32 X 2.0 PHP	6

PROPRIETARY AND CONFIDENTIAL  
THE INFORMATION CONTAINED IN  
THIS DRAWING IS THE SOLE  
PROPERTY OF  
PULSAFEEDER SPO. ANY  
REPRODUCTION IN PART OR AS A  
WHOLE WITHOUT THE WRITTEN  
PERMISSION OF PULSAFEEDER  
IS PROHIBITED.

UNLESS OTHERWISE SPECIFIED:

DIMENSIONS ARE IN INCHES  
TOLERANCES:  
FRACTIONAL: ±1/64  
ANGULAR: ± 1/2°  
X.X=.050in.  
X.XX=.015in.  
X.XXX=.005in.

INTERPRET GEOMETRIC  
TOLERANCING PER:  
ASME Y14.5M-1994

MATERIAL (SEE NOTES)

FINISH (SEE NOTES)

DO NOT SCALE DRAWING

	NAME	DATE
DRAWN	PEC	12-17-07
ENG APPR.	MD	01-10-08

COMMENTS:



TITLE: **SKID ASSEMBLY,  
DUPLEX/STANDARD,  
VITON SEALS**

SIZE	DWG. NO.	REV
<b>B</b>	<b>PES2S-V</b>	<b>C</b>

SCALE: 1:1

SHEET 1 OF 1