

REVISIONS			
REV.	DESCRIPTION	DATE	APPROVED
A	RELEASE ECO 00203	10-16-08	MD
B	ADD LONGER SCREWS FOR NEW SPACERS ECO 00334	01/08/10	JH

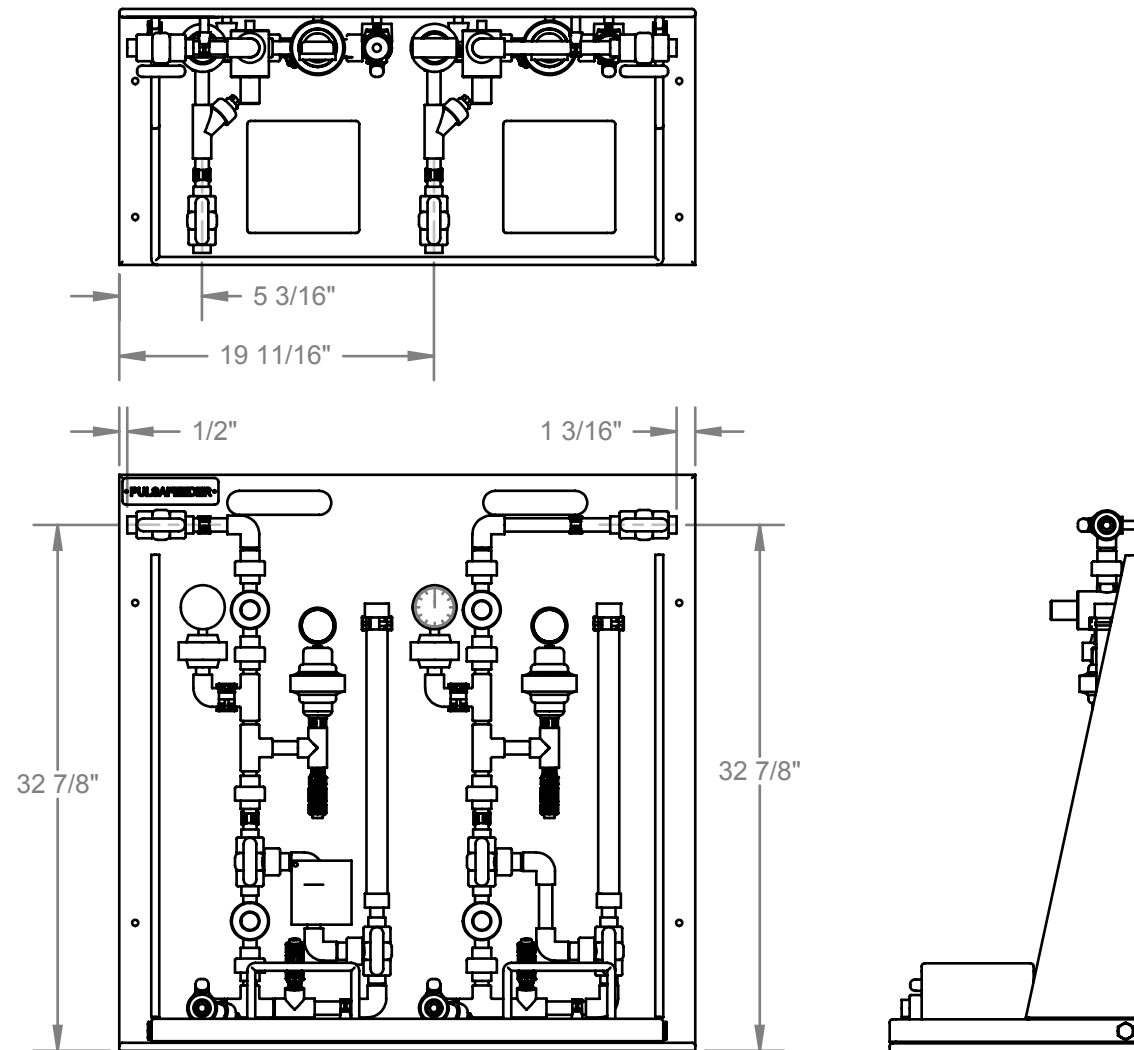

LIST OF MATERIAL
(PUMP MOUNTING)

ITEM NO.	PART NUMBER	DESCRIPTION	QTY.
1	PES00013	SKID BASE WELDMENT, (STANDARD/DUPLEX)	1
2	PES00019CF-001	PIPING ASSEMBLY, LT, COLUMN FILL (VITON)	1
3	PES00018CF-001	PIPING ASSEMBLY, RT, COLUMN FILL (VITON)	1
4	03-043-00	PLUG, PVC-80, 1/2" T	2
5	J25334	PULSAFEEDER NAME PLATE	1
6	06-011-02	#10-32 TEE NUT	14
7	U0810036	SCREW #10-32 X 1.7"	10
8	L9801300-188	#10 FLAT WASHER	14
9	U0810386	SCREW, #10-32 X 1"	8
10	L9804000-000	#10-32 LOCK NUT	8
11	U0900857	SCREW, (SST) 6-20 X .38 TYPE-BT PHP	2
12	PES00032	CARD, COLUMN FILL, LAMINATED	1
13	J42310	CABLE TIE	1
14	L9803300-188	SCREW(SST), #10-32 X 2.0 PHP	4

UNLESS OTHERWISE SPECIFIED:

DIMENSIONS ARE IN INCHES
TOLERANCES:
FRACTIONAL: ±1/64
ANGULAR: ± 1/2°
X.X=.050in.
X.XX=.015in.
X.XXX=.005in.

INTERPRET GEOMETRIC TOLERANCING PER: ASME Y14.5M-1994

MATERIAL (SEE NOTES)

FINISH (SEE NOTES)

DO NOT SCALE DRAWING

	NAME	DATE
DRAWN	PEC	10-16-08
ENG APPR.	MD	10-16-08

COMMENTS:



TITLE:
**SKID ASSEMBLY,
DUPLEX/STANDARD,
(COL FILL) VITON SEALS**

SIZE	DWG. NO.	REV
B	PES2S-VCF	B

SCALE: 1:1

SHEET 1 OF 1

PROPRIETARY AND CONFIDENTIAL
THE INFORMATION CONTAINED IN
THIS DRAWING IS THE SOLE
PROPERTY OF
PULSAFEEDER SPO. ANY
REPRODUCTION IN PART OR AS A
WHOLE WITHOUT THE WRITTEN
PERMISSION OF PULSAFEEDER
IS PROHIBITED.