

REVISIONS			
REV.	DESCRIPTION	DATE	APPROVED
A	RELEASE	03-24-09	MB
B	ADD LONGER SCREWS FOR NEW SPACERS ECO 00334	01/08/10	JH

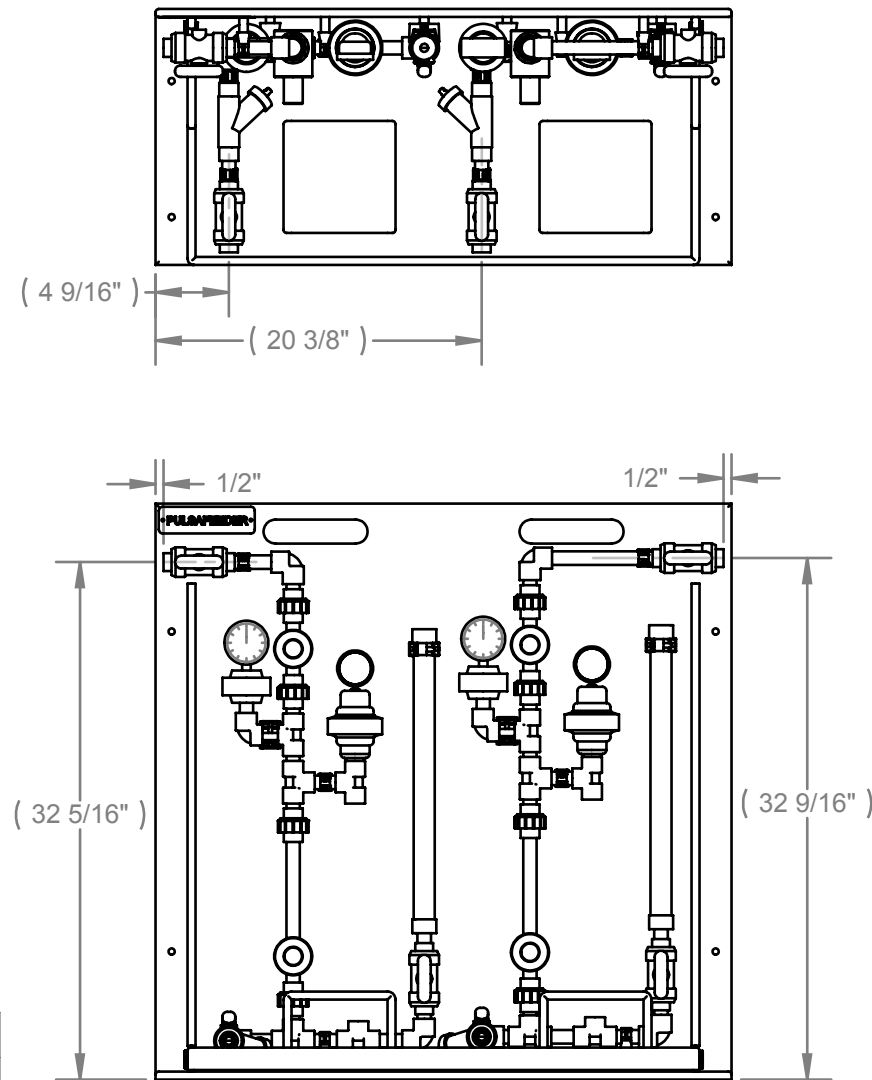

BILL OF MATERIAL

ITEM NO.	PART NUMBER	DESCRIPTION	QTY.
1	PES00013	SKID BASE WELDMENT, (STANDARD/DUPLEX)	1
2	PES00019-003	PIPING ASSEMBLY, DUPLEX LT - STANDARD (PVDF)(VITON SEALS)	1
3	PES00018-003	PIPING ASSEMBLY, SIMPLEX/DUPLEX RT - STANDARD (PVDF) (VITON SEALS)	1
4	03-043-00	PLUG, PVC-80, 1/2" T	2
5	J25334	PULSAFEEDER NAME PLATE	1
6	06-011-02	#10-32 TEE NUT	14
7	U0810036	SCREW #10-32 X 1.7"	8
8	L9801300-188	#10 FLAT WASHER	14
9	U0810386	SCREW, #10-32 X 1"	8
10	L9804000-000	#10-32 LOCK NUT	8
11	U0900857	SCREW, (SST) 6-20 X .38 TYPE-BT PHP	2
12	L9803300-188	SCREW(SST), #10-32 X 2.0 PHP	6

UNLESS OTHERWISE SPECIFIED:

DIMENSIONS ARE IN INCHES
 TOLERANCES:
 FRACTIONAL: ±1/64
 ANGULAR: ± 1/2°
 X.X=.050in.
 X.XX=.015in.
 X.XXX=.005in.

INTERPRET GEOMETRIC TOLERANCING PER: ASME Y14.5M-1994

MATERIAL (SEE NOTES)

FINISH (SEE NOTES)

DO NOT SCALE DRAWING

	NAME	DATE
DRAWN	PEC	03-23-09
ENG APPR.	MB	03-23-09
CHECKED:	MB	03-23-09

COMMENTS:



TITLE: **SKID ASSEMBLY, DUPLEX/STANDARD, (PVDF) VITON SEALS**

SIZE	DWG. NO.	REV
B	PES2S-VK	B

SCALE: 1:1 SHEET 1 OF 1

PROPRIETARY AND CONFIDENTIAL THE INFORMATION CONTAINED IN THIS DRAWING IS THE SOLE PROPERTY OF PULSAFEEDER SPO. ANY REPRODUCTION IN PART OR AS A WHOLE WITHOUT THE WRITTEN PERMISSION OF PULSAFEEDER IS PROHIBITED.