

REV.	DESCRIPTION	DATE	MOD	CHK'D
A	RELEASED	9/21/2016	CAW	LAC

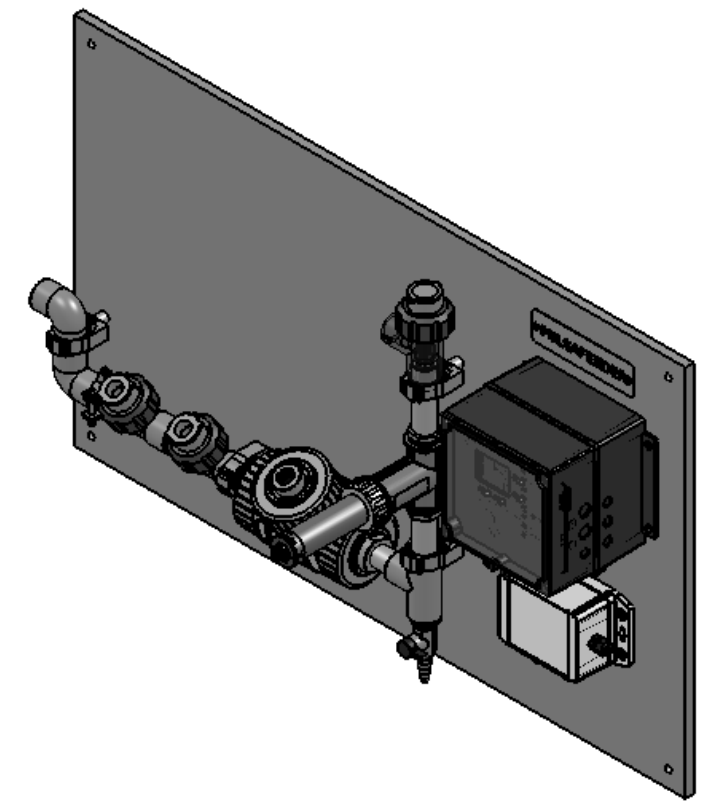
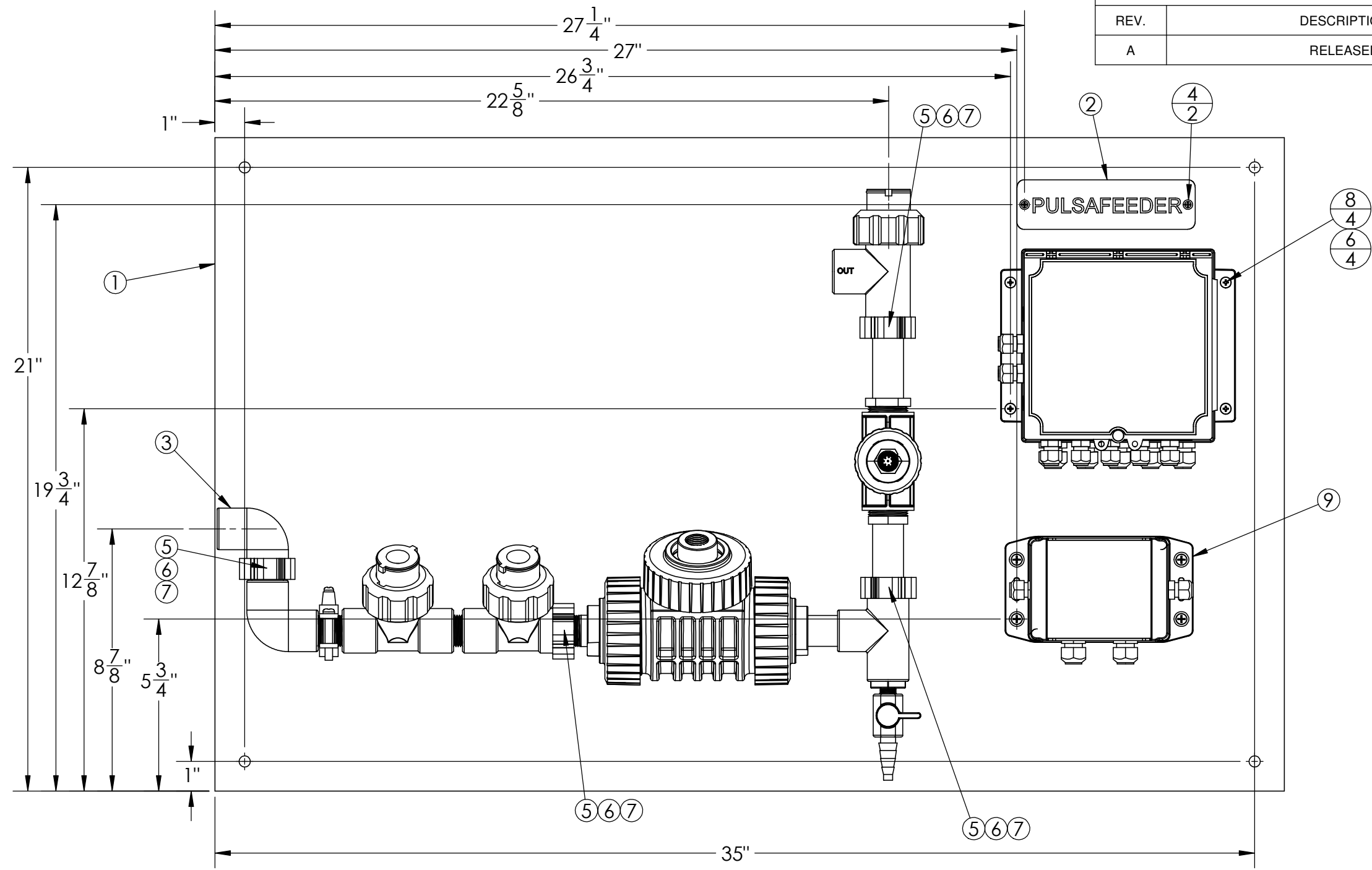

ITEM NO.	PART NUMBER	DESCRIPTION	QTY.
1	02-301-35	PANEL,22X36,POLYETHYLENE	1
2	J25334	LABEL(LEXAN), LOGO NAMEPLATE	1
3	16-600-08	PIPING ASY, PTSA WITH 3 PROBES	1
4	U0900857	SCR(SST),6-20 X.38 TYPE-BT PHP	2
5	U0813501	SCR,PH,SST, 10-32 1.50	4
6	06-011-02	TEE NUT,10-32,.24BARREL,3PRONG	8
7	06-058-00	SPACER(PVC),10-0, 1"- LG	4
8	U0811415	SCREW(SST), 10-32 X .75-LG PHP	4
9	72-901-10	PWR,ASSEM,4-20mA	1

TOLERANCE		MACHINED SURFACES ROUGHNESS 125Ra	DWN	CAW	09/21/2016
X.X"	± .050"				
X.XX"	± .015"				
X.XXX"	± .005"				
ANGLES ± 0°30'		CHK	LAC	09/26/2016	
BREAK ALL SHARP EDGES .015" MAX. ALL DIMENSIONS IN INCHES					
PROPRIETARY DATA: THIS DOCUMENT DISCLOSES INFORMATION AND DATA IN WHICH PULSAFEEDER HAS PROPRIETARY RIGHTS. THE RIGHT TO REPRODUCE, USE OR DISCLOSE IN WHOLE OR IN PART EXCEPT BY WRITTEN PERMISSION IS PROHIBITED.					

**PULSAFEEDER** IDEX CORPORATION

TITLE **PANEL ASSY, MVEX,PTSA, TURNER,COND, 2 TEE**

REV **A** SIZE **B** DWG NO **15-100-52**

FILE **15-100-52** SCALE: 1:4 SHEET **1** OF **1**